

**Omnidirectional
Incandescent Appearance
12-Inch (300-mm) LED Arrows
Compliant to: ITE VTCSH -
LED Vehicle Arrow Traffic Signal Supplement Adopted
July 1, 2007**

Key Features:

- **All Modules Must Meet The ITE VTCSH – LED Vehicle Arrow Traffic Signal Supplement, Adopted July 1, 2007, Over the Full Temperature Range of -40°C to +74°C (Including Yellow Modules)**
- **All Modules Must Be Omnidirectional As Defined In The ITE VTCSH – LED Vehicle Arrow Traffic Signal Supplement Adopted July 1, 2007**
- **ETL/Intertek Certified Testing Reports Required To Verify Full compliance To The ITE VTCSH – LED Vehicle Arrow Traffic Signal Supplement Adopted July 1, 2007**
- **Red and Green Modules Shall Meet Energy Star Power Limits**
- **Uniform Non-pixelated Illumination Meets ITE Requirements**
- **Color Uniformity Exceeds ITE Standards**
- **Transient Suppression Exceeds ITE Requirements**
- **Advanced Failed State Impedance Protection**
- **Turn-on/Turn-off Time < 75 Milliseconds**
- **Hard-Coated Convex Lens Reduces Sun Reflections**
- **Conformally Coated Power Supply**
- **All Products Traceable by Serial Number**

Types:

12" (300-mm) 120VAC Arrows
Red Arrow
Yellow Arrow
Green Arrow

1. Purpose

The purpose of this specification is to provide the minimum performance requirements for 300 mm (12 in) LED vehicle arrow traffic signal modules. This specification is not intended to impose restrictions upon specific designs and materials that conform to the purpose and the intent of this specification. This specification refers to definitions and practices described in “Vehicle Traffic Control Signal Heads” published in the *Equipment and Materials Standards of the Institute of Transportation Engineers*, referred to in this document as “VTCSH.”

2. Definitions

The following definitions are in addition to the definitions in the VTCSH.

2.1 Catastrophic Failure. The total loss of visible illumination from the LED light source.

2.2 Chromaticity. The color of the light emitted by the module, specified as x, y chromaticity coordinates on the chromaticity diagram according to the 1931 Commission Internationale d’Eclairage (CIE) standard observer and coordinate system.

2.3 Conditioning. Energizing a LED signal module at a specified ambient temperature for a specified period of time, to cause any early electronic component mortality failures to occur and to detect any component reliability problems.

2.4 Duty Cycle. The fraction of time during a specified time period that the module is energized, expressed as a percent of the specified time period.

2.5 Abrasion Resistance Material. A surface coating or integral material used to provide outer front lens surface abrasion resistance.

2.6 LED Light Source. An array of light emitting diodes (LEDs).

2.7 LED Vehicle Arrow Traffic Signal Module (module). A signaling unit comprised of an array of LEDs and related power supply, and any required lenses, which, when connected to appropriate power, provides a vehicle arrow traffic signal indication.

2.8 Luminance. The luminous flux emitted or reflected from a surface, in a given direction, per unit solid angle, divided by the area of the surface, expressed as cd/m^2 .

2.9 Luminous Intensity. The luminous flux emitted in a given direction from a source, per unit solid angle, expressed in candelas (cd).

2.10 Minimum Maintained Luminous Intensity. The minimum luminous intensity a module is required to provide throughout service as a traffic control signal.

2.11 Nominal Operating Voltage. The AC RMS voltage, 120 VAC, at which photometric performance and power consumption are specified.

2.12 Omnidirectional Module. An LED vehicle arrow traffic signal module that provides the same luminous intensity signal to the driver regardless of the orientation of the arrow icon within the signal housing.

2.13 Power Consumption. The electrical power in Watts consumed by the module when operated at nominal operating voltage and ambient operating temperature range.

2.14 Power Factor (PF). PF equals Watts divided by Volt-Ampere (VA) or the ratio of power consumption in Watts to Volt-Amperes.

2.15 Total Harmonic Distortion (THD). THD is the ratio of the root-mean-square (RMS) value of the harmonics to the amplitude of the fundamental component of the ac waveform.

2.16 Translate. To move an object along a linear vector, such that the orientation of the object does not rotate relative to the original frame of reference.

2.17 Turn OFF Time. The amount of time required after removal of the nominal operating voltage for the LED signal module to show no visible illumination.

2.18 Turn OFF Voltage. The voltage below which the LED signal module emits no visible illumination.

3.19 Turn ON Time. The amount of time required for the LED signal module to reach 90% of full illumination.

3.20 Volt-Amperes. The product of root-mean-square (RMS) line voltage and RMS line current measured with true RMS meter.

3. Physical and Mechanical Requirements

3.1 General

3.1.1 Modules shall fit into existing traffic signal housings built to the VTCSH Standard without modification to the housing, or shall be stand-alone units that incorporate a housing meeting the performance and design requirements of the VTCSH Standard.

3.1.2 Installation of a module into an existing signal housing shall not require the use of special tools. The module shall connect directly to existing electrical wiring system. Screw-in type LED modules shall be prohibited.

3.1.3 All modules including yellow, shall **completely** comply with the ITE VTCSH – LED Vehicle Arrow Traffic Signal Supplement. All modules, including yellow, shall meet or exceed minimum maintained luminous intensity requirements, and uniformity requirements, even at 74° centigrade.

3.1.4 ETL/Intertek certified test reports are required to verify full compliance to ITE VTCSH - LED Vehicle Arrow Traffic Signal Supplement.

3.2 LED Signal Module

3.2.1 A module shall be capable of replacing the existing optical components or signal module in a signal housing.

3.2.2 The module's outer spreading lens shall be hard coated or otherwise made to comply with the material exposure and weathering effects requirements of the Society of Automotive Engineers (SAE) J576.

3.2.3 Tinting (Optional) - The lens may be tinted or covered by transparent film or materials with similar color and transmissive characteristics.

3.2.4 The module lens shall be securely attached using a waterproof silicone seal.

3.2.5 The general configuration of the arrow icon is illustrated in Figure 1. The arrow should be oriented in the direction of its intended use.

3.3 Environmental Requirements

3.3.1 All exposed components of a module shall be suitable for prolonged exposure to the environment, without appreciable degradation that would interfere with function or appearance. As a minimum, selected materials shall be rated for service for a period of a minimum of 60 months in a south-facing Arizona Desert installation.

3.3.2 A module shall be rated for use throughout an ambient operating temperature range, measured at the exposed rear of the module, of -40°C (-40°F) to +74°C (+165°F).

3.3.3 A module shall be protected against dust and moisture intrusion, including rain and blowing rain.

3.3.4 The module lens shall not crack, craze or yellow due to solar UV irradiation typical for a south-facing Arizona Desert installation after a minimum of 60 months in service.

3.4 Construction

3.4.1 A module shall be a self-contained device, not requiring on-site assembly for installation into an existing traffic signal housing. The power supply for the module shall be securely mounted in a molded pocket on the interior side wall of the module. The power supply shall be conformally coated.

3.4.2 Assembly and manufacturing processes for the module shall be designed to assure all internal LED and electronic components are adequately supported to withstand mechanical shock and vibration due to high winds and other sources.

3.4.3 Each LED module shall incorporate two separate printed circuit boards, one for the LED light source, and the other for the power supply.

3.4.4 The module shall incorporate a single lens approach. In order to optimize *optical efficiency*;

definition of the arrow icon; and *uniformity*; an arrow cookie-cutter shall be incorporated behind the outer lens. The cookie-cutter shall be solidly attached to the LED printed circuit board with screws, surround the perimeter of the LED array, and extend from the surface of the LED printed circuit board towards the lens surface.

3.4.5 The outer lens shall be smooth on its exterior surface so as to minimize the collection of dirt, debris, and other particulate contaminants which may impact luminous intensity, and to facilitate periodic lens cleaning. External lens facets shall be prohibited.

3.4.6 The outer lens of the LED module shall be a permanent integral part of the module and shall be convex in order to reduce sun reflections. The emitting surface of the lens for 12" (300mm) modules shall be a minimum of 11.05" in diameter.

3.5 Materials

3.5.1 Materials used for the lens and module construction shall conform to ASTM specifications for the materials where applicable.

3.5.2 Enclosures containing either the power supply or electronic components of the module shall be made of UL94 flame retardant materials. The module lens is excluded from this requirement.

3.6 Module Identification

3.6.1 Each module shall be identified on the backside with the manufacturer's name, model, operating characteristics and serial number. The operating characteristics identified shall include the nominal operating voltage and stabilized power consumption, in watts and Volt-Amperes. The main module label which includes the module's serial number (or date code) and the model number shall be attached using polyester or vinyl self-adhesive labels. The use of paper labels is not acceptable.

3.6.2 Omnidirectional modules shall be clearly marked with the phrase "Suitable for mounting in any orientation".

3.6.3 Modules conforming to all non-optional

requirements of this specification may have the following statement on an attached label: "Manufactured in Conformance with the ITE LED Vehicle Arrow Traffic Signal Supplement."

4. Photometric Requirements

4.1 Luminous Intensity, Uniformity & Distribution

4.1.1 Minimum maintained luminous intensity: When operated under the conditions defined in Sections 3.3.2 and 5.2.1, the luminous intensity values for modules shall not be less than the values calculated using the method described below for a minimum period of 60 months.

4.1.1.1 For omnidirectional LED vehicle arrow traffic signal modules, calculate the intensity factor ($f(I_{OD})$) for the range from 27.5 degrees up to 27.5 degrees down, and for 27.5 degrees left to 27.5 degrees right using the following equation:

$$f(I_{OD}) = 1.02 * e^{(-0.0038 * \theta_{OD}^2)}$$

where: $\theta_{OD} = \cos^{-1}(\cos(\theta_{Vert}) * \cos(\theta_{Horiz}))$, θ_{Vert} is the angle measured above or below a horizontal plane perpendicular to the face of the module lens, and θ_{Horiz} is the angle measured to the left or right from a vertical plane perpendicular to the face of the module lens. All angles are measured in degrees. Round the result to two significant figures.

4.1.1.1.1 Multiply the intensity factor ($f(I_{OD})$) by the appropriate peak minimum maintained luminous intensity value for the specified module color: Red—58.4 cd, Yellow—145.6 cd, and Green—76.0 cd. Round the resultant value of the luminous intensity to the first decimal place.

4.1.1.1.2. For the region where θ_{Vert} is between 2.5 degrees up and 2.5 degrees down, and θ_{Horiz} is between 2.5 degrees left and 2.5 degrees right, the values shall be the same as those calculated for $\theta_{Vert} = 2.5$ degrees and $\theta_{Horiz} = 2.5$ degrees.

4.1.1.1.3. There are no requirements for the region where $\theta_{OD} > 30$ degrees.

4.1.1.2 Table 1 provides the minimum maintained

luminous intensity values for omnidirectional modules, over the required angular range, at 5-degree increments.

4.1.1.3 Table 1 is provided to illustrate the minimum required values at certain specific angles within the required angular range of performance (i.e. while testing for light output compliance of a module in a laboratory, an agency may use Table 1 and/or other specific pairs of vertical and horizontal angles of its choosing within the required angular range.) One must use the procedures outlined above for determining the minimum maintained luminous intensity values at any specific pairs of vertical and horizontal angles within the required angular range.

4.1.2 Maximum permissible luminous intensity: When operated within the temperature range specified in Section 3.3.2, the actual luminous intensity for a module shall not exceed three times the required peak value of the minimum maintained luminous intensity for the selected signal color.

4.1.3 Luminance uniformity: The uniformity of the signal output across the emitting section of the module lens (i.e. the arrow icon) shall not exceed a ratio of 10 to 1 between the maximum and minimum luminance values (cd/m^2).

4.2 Chromaticity

4.2.1 Color regions: The measured chromaticity coordinates of modules shall conform to the color regions specified in the VTCSH LED Circular Signal Supplement.

4.2.2 Color uniformity: The uniformity of the emitted color of a module shall conform to the requirements specified in the VTCSH LED Circular Signal Supplement.

5. Electrical

5.1 General

5.1.1 All wiring shall meet the requirements of Section 13.02 of the VTCSH standard. Two (2) secured, color coded, 600V, anti-capillary, 18 AWG jacketed wires, 1 meter (39 in) in length, conforming to the NFPA 70, National Electrical

Code, and rated for service at $+105^\circ\text{C}$, shall be provided.

5.1.2 The wire leads shall exit the module via a rubber grommetted strain relief, and shall be terminated with quick connect terminals and spade tab adapters. The two leads shall be separate at the point at which they leave the module. One of the conductors shall have white insulation to signify neutral. The color of the other conductor shall be different and shall be used to differentiate between red, yellow, and green arrow LED modules.

5.1.3 The following AC power wire lead color code standard for vehicular arrow traffic signal LED modules shall be followed:

Red Arrow:	Red & White wires
Yellow Arrow:	Yellow & White wires
Green Arrow:	Brown & White wires

5.2 Voltage Range

5.2.1 The modules shall operate from a 60 ± 3 Hertz AC power line over a voltage range from 80 to 135 VAC RMS.

5.2.2 Fluctuations in line voltage over the range of 80 to 135 VAC RMS shall not affect luminous intensity by more than ± 10 percent.

5.2.3 The module circuitry shall prevent flicker of the LED output at frequencies less than 100 Hz over the voltage range specified in Section 5.2.1.

5.2.4 Low Voltage Turn Off: There shall be no visible illumination from the module when the applied voltage is less than 35 VAC RMS.

5.2.5 Turn-ON and Turn-OFF Time: A module shall reach 90% of full illumination (turn-ON) within 75 msec of the application of the nominal operating voltage. The signal shall cease emitting visible illumination (turn-OFF) within 75 msec of the removal of the nominal operating voltage.

5.3 Transient Voltage Protection

The on-board circuitry of a module shall include voltage surge protection, to withstand high-repetition noise transients and low-repetition high-energy transients as stated in Section 2.1.6,

NEMA Standard TS 2-2003. In addition, the module shall comply with the following standards: IEC 1000-4-5 at 3kV with a 2 ohm source impedance, ANSI/IEEE C62, 41-2002; IEC 61000-4-12 (6kV, 200A, 100kHz ring wave).

5.4 Electronic Noise

The LED signal and associated on-board circuitry shall meet the requirements of the Federal Communications Commission (FCC) Title 47, Subpart B, Section 15 regulations concerning the emission of electronic noise by Class A digital devices.

5.5 Power Factor (PF) and AC Harmonics

5.5.1 Modules shall provide a power factor of 0.90 or greater when operated at nominal operating voltage, and at 25°C (77°F).

5.5.2 Total harmonic distortion induced into an AC power line by a module at nominal operating voltage, and at 25°C (77°F), shall not exceed 20%.

5.6 Controller Assembly Compatibility

5.6.1 The current draw shall be sufficient to ensure compatibility and proper triggering and operation of load current switches and conflict monitors in signal controller units.

5.6.2 Off State Voltage Decay: When the module is switched from the On state to the Off state the terminal voltage shall decay to a value less than 10 VAC RMS in less than 100 milliseconds when driven by a maximum allowed load switch leakage current of 10 milliamps peak (7.1 milliamps AC).

5.7 Failed State Impedance

The module shall be designed to detect catastrophic loss of the LED load. Upon sensing the loss of the LED load, the module shall present a resistance of at least 250 kΩ across the input power leads within 300 msec. The LED light source will be said to have failed catastrophically if it fails to show any visible illumination when energized according to Section 5.2.1 after 75 msec.

6. Quality Assurance

6.1 General

6.1.1 Quality Assurance Program: Modules shall be manufactured in accordance with a vendor quality assurance (QA) program. The QA program shall include two types of quality assurance: (1) design quality assurance and (2) production quality assurance. The production quality assurance shall include statistically controlled routine tests to ensure minimum performance levels of modules built to meet this specification.

6.1.2 Record Keeping: QA process and test results documentation shall be kept on file for a minimum period of seven years.

6.1.3 Conformance: Module designs not satisfying design qualification testing and the production quality assurance testing performance requirements in Sections 6.3 and 6.4 shall not be labeled, advertised, or sold as conforming to this specification.

6.2 Manufacturers Serial Numbers

Each module shall be identified with the information specified in paragraph 3.6.1.

6.3 Production Tests & Inspections

6.3.1 Production Test Requirements: All modules tendered for sale shall undergo the following Production Testing & Inspection prior to shipment. Failure of a module to meet the requirements of Production Testing & Inspection shall be cause for rejection. Test results shall be maintained per the requirement of Section 6.1.2.

6.3.1.1 All Production Tests shall be performed at an ambient temperature of 25°C (77°F) and at the nominal operating voltage of 120 VAC.

6.3.2 Luminous Intensity: All modules shall be tested for luminous intensity. A single point measurement, with a correlation to the intensity requirements of Sections 4.1.1 and 4.1.2 may be used. The purchaser may specify additional measurements. Failure of a module to meet the requirements for minimum maintained luminous intensity (4.1.1) or maximum permissible

luminous intensity (4.1.2) shall be cause for rejection of the module.

6.3.3 Power Factor: All modules shall be tested for power factor per the requirements of Section 5.5.1. A commercially available power factor meter may be used to perform this measurement. Failure of a module to meet the requirements for power factor (5.5.1) shall be cause for rejection of the module.

6.3.4 Current Consumption Measurement: All modules shall be measured for current flow in Amperes. The measured current values shall be compared against the design current values from design qualification measurements in Section 6.4.6.1. A measured current consumption in excess of 120% of the design qualification current value for an ambient temperature of 25°C (77°F) shall be cause for rejection of the module.

6.3.5 Visual Inspection: All modules shall be visually inspected for any exterior physical damage or assembly anomalies. Careful attention shall be paid to the surface of the lens to ensure there are no scratches (abrasions), cracks, chips, discoloration, or other defects. The presence of any such defects shall be cause for rejection of the module.

6.4 Design Qualification Testing

6.4.1 Design Qualification Test Requirements. Design qualification testing shall be performed on new module designs, when a major design change has been implemented on an existing design, or after every 5 years that a design is in service. Modules used in design qualification testing shall be representative of the manufacturer's proposed normal production. If modules are provided with both clear and tinted lenses, the tests for Temperature Cycling (6.4.3.2), Moisture Resistance (6.4.3.3), Luminous Intensity (6.4.4.1), Luminance Uniformity (6.4.4.5), Chromaticity (6.4.4.6), Color Uniformity (6.4.4.7), and Lens Abrasion (6.4.5.2) shall be conducted for all lens types. The certification of UV Stabilization (6.4.5.2) shall be provided for all materials used in or on the emitting lenses.

6.4.1.1 Test data shall be retained by the

manufacturer in accordance with Section 6.1.2 or for 60 months following final production of a specific design, whichever is longer.

6.4.1.2 Six modules shall be used in Design Qualification Testing. All six modules shall be subjected to conditioning (6.4.2), followed by the Environmental Tests (6.4.3). Following the Environmental Tests, three modules shall undergo Photometric & Colorimetric Tests (6.4.4), followed by the Lens Abrasion Test (6.4.5). The remaining three modules shall undergo the Electrical Tests (6.4.6), the Controller Assembly Compatibility Tests (6.4.7), and the Failed State Impedance Test (6.4.8). Tests shall be conducted in the order described herein, unless otherwise specified.

6.4.1.3 In order for a module design to be considered acceptable for marking with the label described in 3.6.4, all tested modules must comply with the acceptance/rejection criteria for the Environmental Tests (6.4.3), Photometric & Colorimetric Tests (6.4.4), Lens Tests (6.4.5), Electrical Tests (6.4.6), Controller Assembly Compatibility Tests (6.4.7), and the Failed State Impedance Test (6.4.8).

6.4.2 Conditioning: Modules shall be energized for a minimum of 24 hours, at 100% duty cycle, in an ambient temperature of +60°C (+140°F).

6.4.3 Environmental Tests:

6.4.3.1 Mechanical Vibration: Mechanical vibration testing shall be performed per MIL-STD-883, Test Method 2007, using three 4 minute cycles along each x, y, and z axis, at a force of 2.5 Gs, with a frequency sweep from 2 Hz to 120 Hz.

6.4.3.2 Temperature Cycling: Temperature cycling shall be performed per MIL-STD-883, Test method 1010. The temperature range shall include the full ambient operating temperature range specified in 3.3.2. A minimum of 20 cycles shall be performed with a 30-minute transfer time between temperature extremes and a 30-minute dwell time at each extreme temperature. Signals under test shall be non-operating.

6.4.3.3 Moisture Resistance: Moisture resistance testing shall be performed per MIL-STD-810F, Test Method 506.4, Procedure I, Rain and Blowing Rain. The test shall be conducted on stand-alone modules, without a protective housing. The rainfall rate shall be 1.7 mm/min (4 in/hr) and droplet size shall predominantly be between 0.5 mm and 4.5 mm (0.02 to 0.18 in). The modules shall be vertically oriented, such that the lens is directed towards the wind source when at a zero rotation angle. The module shall be rotated at a rate of 4 degrees per minute along the vertical axis, from an orientation of -60 to +60 degrees during the test. The duration of the test shall be 30 minutes. The modules shall be energized throughout the test. The water shall be at $25^{\circ} \pm 5^{\circ}\text{C}$ ($77^{\circ} \pm 9^{\circ}\text{F}$). The wind velocity shall be 80 km/hr (50 mph). If the module is equipped with a remote power supply unit, then the test shall be conducted with the remote power supply unit attached to the clamping device holding the module to the test apparatus.

6.4.3.4 Environmental Tests Evaluation: At the conclusion of the Environmental Tests, all the modules will be visual inspected for damage and energized to insure proper operation.

6.4.3.5 Acceptance/Rejection Criteria: The loosening of the lens, or any internal components, or evidence of other physical damage, such as cracking of the module lens or housing, or presence of internal moisture, or failure to operate correctly after testing shall be considered a failure for the proposed design.

6.4.4 Photometric & Colorimetric Tests: Three of the modules that were subjected to the Environmental Tests shall undergo Photometric & Colorimetric Tests. Unless otherwise specified, these tests shall be performed with the modules energized at nominal operating voltage.

6.4.4.1 Luminous intensity at standard temperature: The modules shall be tested for compliance with the requirements for minimum maintained luminous intensity at a temperature of 25°C (77°F). Measurements shall be made for all angular combinations specified in Table 1.

6.4.4.1.1 Luminous intensity measurements for red and green signal modules shall be made after

the module has been operated under the test conditions for a minimum of 60 minutes at a 100% duty cycle.

6.4.4.1.2 Luminous intensity measurements for yellow signal modules shall be made after the module has been operated under the test conditions for a minimum of 60 minutes at a 12.5% duty cycle (5 seconds ON and 35 seconds OFF). Readings shall be taken at the end of the 5-second ON interval, or as close to the end of the ON interval as possible.

6.4.4.2 Luminous intensity at low voltage: The modules shall be tested for compliance with the requirements for minimum maintained luminous intensity when operated at 80 VAC at a temperature of 25°C (77°F). A single-point measurement of the luminous intensity shall be recorded, and correlated to the measurement made in the same direction under Section 6.4.4.1 to generate a full range of luminous intensity values at reduced voltage. The single point measurement shall be taken in the region from 0 to 7.5 degrees down and from 7.5 degrees left to 7.5 degrees right. The luminous intensity measurement at reduced voltage shall be made immediately following measurements for luminous intensity at standard temperature (6.4.4.1).

6.4.4.3 Luminous intensity at elevated voltage: The modules shall be tested for compliance with the requirements for minimum maintained luminous intensity when operated at 135 VAC at a temperature of 25°C (77°F). A single-point measurement of the luminous intensity shall be recorded, and correlated to the measurement made in the same direction under Section 6.4.4.1 to generate a full range of luminous intensity values at elevated voltage. The single point measurement shall be taken in the region described in Section 6.4.4.2. The luminous intensity measurement at elevated voltage shall be made immediately following measurements for luminous intensity at reduced voltage (6.4.4.2).

6.4.4.4 Luminous intensity at high temperature: The modules shall be tested for compliance with the requirements for minimum maintained

luminous intensity at a temperature of 74°C (165°F). The modules shall be mounted in a temperature chamber so that the signal module lens is outside the chamber and all portions behind the lens are within the chamber at a temperature of 74°C (165°F). The air temperature in front of the lens of the signal shall be maintained at a minimum of 49°C (120°F) during all tests. A single-point measurement of the luminous intensity shall be recorded, and correlated to the 25°C (77°F) measurement made in the same direction under Section 6.4.4.1 to generate a full range of luminous intensity values at high temperature. The single point measurement shall be taken in the region described in Section 6.4.4.2.

6.4.4.4.1 Luminous intensity measurements for red and green modules shall be made after the module has been operated under the test conditions for a minimum of 60 minutes at a 100% duty cycle.

6.4.4.4.2 Luminous intensity measurements for yellow modules shall be made after the module has been operated under the test conditions for a minimum of 60 minutes at a 12.5% duty cycle (5 seconds ON and 35 seconds OFF). Readings shall be taken at the end of the 5-second ON interval, or as close to the end of the ON interval as possible.

6.4.4.5 Luminance uniformity: The modules shall be tested for compliance with the requirements for luminance uniformity at a temperature of 25°C (77°F). Measurements shall be made using a luminance meter located on the physical axis of the module lens at a distance such that the selected aperture samples a circular spot with a diameter of 12mm (0.5 inch) at the lens surface. The position of the luminance meter shall be translated from side to side and up and down, so as to sample the entire emitting surface of the module. The highest and lowest values of luminance shall be recorded. Luminance measurements may be made immediately following measurements for luminous intensity at standard temperature and elevated voltage (6.4.4.3), after returning the voltage to the nominal operating voltage (120VAC).

6.4.4.5.1 Luminance uniformity measurements for the green and red signals must be made with the signal module operating at a 100% duty cycle. Therefore, it is necessary for the signal module under test to reach thermal equilibrium, and for the output to be stable prior to taking measurements.

6.4.4.5.2 Measurements for yellow signal modules shall be made after the module has been operated under the test conditions for a minimum of 60 minutes at a 12.5% duty cycle (5 seconds ON and 35 seconds OFF). Readings shall be taken at the end of the 5-second ON interval, or as close to the end of the ON interval as possible.

6.4.4.6 Chromaticity: The chromaticity of the emitted light from modules shall be measured at a temperature of 25°C (77°F). A spectro-radiometer with a maximum bandwidth of 4nm, or a colorimeter that has a measurement uncertainty of less than 2.5% over the emission spectra of the module, shall be used for this measurement. The spectro-radiometer or colorimeter shall be located on the physical axis of the module lens at a distance such that the selected aperture samples a circular spot with a diameter of 12mm (0.5 inch) at the lens surface. The meter shall be translated from side to side and up and down, so as to sample a minimum of nine equally distributed positions about the emitting surface of the module. The colorimetric values of the emitted light at each of the nine positions shall be recorded, and an average value calculated, based on the CIE Standard 2° Observer. These measurements may be made immediately following measurements for luminance uniformity (6.4.4.5).

6.4.4.6.1 Chromaticity measurements for the green and red signals must be made with the signal module operating at a 100% duty cycle. Therefore, it is necessary for the signal module under test to reach thermal equilibrium, and for the output to be stable prior to taking measurements.

6.4.4.6.2 Measurements for yellow signal modules shall be made after the module has been operated under the test conditions for a

minimum of 60 minutes at a 12.5% duty cycle (5 seconds ON and 35 seconds OFF). Readings shall be taken at the end of the 5-second ON interval, or as close to the end of the ON interval as possible. If necessary, the ON interval may be extended to 10 seconds to permit completion of a measurement. The ON interval between measurements, however, shall remain 5 seconds.

6.4.4.7 Color uniformity: The average and nine individual sets of chromaticity values of each module under evaluation shall be plotted on the CIE 1931 Chromaticity Diagram (see Figure 1, VTCSH LED Circular Signal Supplement).

6.4.4.8 Photometric & Colorimetric Tests Evaluation: At the conclusion of the Photometric & Colorimetric Tests, the measurement data shall be compared to the applicable requirements of Sections 4.1 and 4.2.

6.4.4.9 Acceptance/Rejection Criteria: The failure of any module to meet any of the following: the requirements for minimum maintained luminous intensity (4.1.1) or maximum permissible luminous intensity (4.1.2) under standard and high temperatures, the requirement for luminance uniformity (4.1.3) or the appropriate requirement for chromaticity (4.2) shall be considered a failure of the proposed design.

6.4.5 Lens Tests: Following the Photometric & Colorimetric Tests, the three modules shall be subjected to the following tests of the acceptability of the lens construction.

6.4.5.1 UV Stabilization: Documentation shall be provided that certifies that the loss of direct transmission through the lens shall not cause the performance of the module to fall below the photometric requirements, or deviate from the colorimetric requirements of this specification after 60 months, or greater as specified by the manufacturer, of service in accordance with 3.3.1 and 3.3.4. Documentation shall be provided for hard-coat film (if used), tinting film or material (if used) and lens material.

6.4.5.2 Lens Abrasion Test: Abrasion resistance testing of the module lens shall be performed as follows:

- a) A lens shall be mounted in the abrasion test fixture with the lens facing upwards.
- b) An abrading pad meeting the requirements in paragraphs c) through f) below shall be cycled back and forth (1 cycle) for 12 cycles at $10\text{cm} \pm 2\text{cm}$ per second over the whole surface of the lens.
- c) The abrading pad shall be not less than $2.5\text{cm} \pm 0.1\text{cm}$ square, constructed of 0000 steel wool and rubber, cemented to a rigid base shaped to the same contour as the lens. The “grain” of the pad shall be perpendicular to the direction of motion.
- d) The abrading pad support shall be equal in size to the pad and the center of the support surface shall be within $\pm 2\text{mm}$ of parallel to the lens surface.
- e) The density of the abrading pad shall be such that when the pad is mounted to its support and is resting unweighted on the lens, the base of the pad shall be no closer than 3.2mm to the lens at its closest point.
- f) When mounted on its support and resting on the lens, the abrading pad shall be weighted such that a pad pressure of $14\text{ kPa} \pm 1\text{ kPa}$ exists at the center and perpendicular to the face of the lens.
- g) A pivot shall be used if required to follow the contour of the lens.
- h) Unused steel wool shall be used for each test.

6.4.5.3 Acceptance/Rejection Criteria: The photometric performance of a module following the lens abrasion test shall be 90% or more of the photometric performance of the same module measured prior to the lens abrasion test. A single point correlation as described in 6.4.4.2 may be used to determine the change in photometric performance. The single point measurement shall be made at an ambient temperature of 25°C (77°F) and nominal voltage of 120VAC. Failure of any module to meet the requirement for photometric performance following the lens abrasion test shall be considered a failure of the proposed design.

6.4.6 Electrical Tests: Three of the modules that were subjected to the Environmental Tests shall undergo Electrical Tests. These tests shall be performed with the modules energized at nominal operating voltage and at a standard temperature of 25°C (77°F), unless specified otherwise.

6.4.6.1 Current Consumption: The current flow, in Amperes, shall be measured at various ambient temperatures across the span of the operating temperature range specified in 3.3.1. The manufacturer shall provide information (charts, tables and/or graphs) on the variation in current through 60 months of service, or greater as specified by the manufacturer, within the operating temperature range of 3.3.2. In addition, the current consumption at start-up shall be measured at 25°C (77°F) to establish the reference value used for Production Quality Assurance (6.3.4).

6.4.6.2 Low-Voltage Turn-OFF: The modules shall be connected to a variable power supply, and energized at nominal operating voltage. The applied voltage shall be reduced to a point where there is no visible illumination from the module when the background is at an average luminance of 0.1 cd/m² (0.01 ft-cd).

6.4.6.3 Turn-ON/Turn-OFF Times: Using a two-channel oscilloscope, the time delay between application of nominal operating voltage and the module reaching 90% of full light output, and the time delay between de-energizing the module and the light output dropping to 0% of full output, shall be measured.

6.4.6.4 Transient Voltage Immunity: The modules shall be tested for transient immunity using the procedure described in Section 2.1.8, NEMA Standard TS 2-2003.

6.4.6.5 Electronic Noise: The modules shall be tested for conformance with the requirements of a Class A digital device, as specified in FCC Title 47, Subpart B, Section 15.109(b).

6.4.6.6 Power Factor: The power factor for the modules shall be measured and recorded. A commercially available power factor meter may be used to perform this measurement.

6.4.6.7 Total Harmonic Distortion (THD): The total harmonic distortion induced into an AC power line by the modules shall be measured and recorded. A commercially available total harmonic distortion meter may be used to perform this measurement.

6.4.6.8 Electrical Tests Evaluation: At the conclusion of the Electrical Tests, the measurement data shall be compared to the requirements of Sections 5.2 through 5.5.

6.4.6.9 Acceptance/Rejection Criteria: The failure of any module to meet the requirements for low-voltage turn-OFF (5.2.4), turn-ON/turn-OFF times (5.2.5), transient voltage immunity (5.3), emission of electronic noise (5.4), minimum power factor (5.5.1), and/or maximum total harmonic distortion (5.5.2) shall be considered a failure of the proposed design.

6.4.7 Controller Assembly Compatibility Tests: Following the Electrical Tests, three modules shall be tested for compatibility with load current switches and conflict monitors presently in service. The manufacturer shall test the design for the specific type signal control unit with which the design is intended to be compatible.

6.4.7.1 Load Switch Compatibility: The modules shall be tested for compatibility and proper operation with load current switches. Each module shall be connected to a variable AC voltage supply. The AC line current into the module shall be measured for sufficient current draw to ensure proper load switch operation while the voltage is varied from 80 to 135 VAC.

6.4.7.2 Off State Voltage Decay Test: Each module shall be operated from a 135 VAC voltage supply. A 19.5 kΩ resistor shall be wired in series in the hot line between the module and the AC power supply. A single-pole-single-throw switch shall be wired in parallel with the 19.5 kΩ resistor. A 220 kΩ shunt resistor shall be wired between the hot line connection and the neutral line connection on the module. Conflict monitor Off state impedance compatibility shall be tested by measuring the voltage decay across the 220 kΩ shunt resistor as follows: The single-pole-single-throw switch shall be closed,

bypassing the 19.5 kΩ resistor and allowing the AC power supply to energize the module. Next, the switch shall be opened and the voltage across the 220 kΩ shunt resistor shall be measured for decay to a value equal to or less than 10 VAC RMS. The test shall be repeated 10 times, with the longest decay time recorded as the final test value.

6.4.7.3 Controller Assembly Compatibility Tests Evaluation: At the conclusion of the Controller Assembly Compatibility Tests, the measurement data shall be compared to the requirements of Section 5.6.

6.4.7.4 Acceptance/Rejection Criteria: Failure of the module to draw sufficient current to ensure compatibility with the load current switches in the appropriate Controller Assembly (5.6.1) and/or failure of the circuit voltage to decay to a value equal to or less than 10 VAC RMS within a time period equal to or less than 100 milliseconds (5.6.2) shall be considered a failure of the proposed design.

6.4.8 Failed State Impedance Test: The modules shall be tested for compliance with the requirement for provision of a failed-state impedance (5.7). The test is conducted in two parts: first the module is energized with the LED load disconnected from the power supply to establish the failed-state impedance. Next, the requirement for the failed state impedance is tested. The module shall be operated from a 120 VAC voltage supply.

- a) Wire a 50 kΩ resistor in series with the hot line between the module and the AC power supply. A 100 kΩ shunt resistor shall be wired between the hot line connection and the neutral line connection on the module. A single-pole-single-throw switch shall be wired in parallel with the 50 kΩ resistor. With the switch in the closed position and the LED load disconnected from the module power supply, energize the module for 300ms to establish the failed state impedance (5.7.2).
- b) The second part of the failed state impedance test is conducted to insure that the appropriate failed state impedance is established. The switch is opened and the

circuit is energized by the 120VAC voltage supply. The voltage across the 100 kΩ shunt resistor shall be continuously monitored. The voltage shall decay to a value equal to or greater than 70 VAC RMS. For the continuous interval of 500 ms through 1500 ms, after energizing the circuit with an open switch, the measured voltage shall be 70 VAC RMS or greater. The second part of the test shall be repeated 10 times, with the minimum voltage recorded during the continuous interval of 500 ms through 1500 ms, after energizing the circuit with an open switch, recorded as the final test value.

6.4.8.1 Failed State Impedance Test Evaluation: At the conclusion of the Failed State Impedance Test, the measurement data shall be compared to the requirement of Section 5.7.

6.4.8.2 Acceptance/Rejection Criteria: Failure of the voltage across the 100 kΩ shunt resistor to remain at a value equal to or greater than 70 VAC RMS for the continuous time interval of 500 ms through 1500 ms, after energizing the circuit with an open switch, shall be considered a failure of the proposed design.

7. Warranty

7.1 Manufacturers shall provide a written warranty issued by the factory located in the NAFTA country of module origin with the following minimum provisions:

7.2 Modules shall be replaced, repaired or purchase value refunded if the module fails to function as intended due to workmanship or material defects within the first 60 months from the date of delivery.

7.3 Modules which exhibit luminous intensities less than the minimum specified values within the first 60 months of the date of delivery shall be replaced, repaired or purchase value refunded.

7.4 Upon request, the LED lamp module manufacturer shall provide written documentation of its ability to satisfy a worst-case, catastrophic warranty claim.

7.4.1 A current corporate annual report duly-certified by an independent auditing firm, containing financial statements illustrating sufficient cash-on-hand and net worth to satisfy a worst-case, catastrophic warranty claim is an example of suitable documentation.

7.4.2 The documentation shall clearly disclose:

- a) The country in which the factory of module origin is located
- b) The name of the company or organization that owns the factory of module origin including any and all of its parent companies and/or organizations, and their respective country of corporate citizenship

7.4.3 For firms with business and/or corporate citizenship in the United States of less than seven years, the process by which the end-users/owners of the modules will be able to obtain worst-case, catastrophic warranty service in the event of bankruptcy or cessation-of-operations by the firm supplying the modules within North America, or in the event of bankruptcy or cessation-of-operations by the owner of the factory of origin, shall be clearly disclosed.

8. Experience

-
The LED module manufacturer shall provide proof of supply of a minimum of 1,000,000 LED traffic signal modules into North America.

Table 1

Table 1 provides the minimum maintained luminous intensity values for the VTCSH Omnidirectional LED Vehicle Arrow Traffic Signal, for the range from 27.5 degrees above to 27.5 degrees below the horizontal plane, and from 27.5 degrees left to 27.5 degrees right of the vertical plane, at 5 degree increments.

Minimum Maintained Luminous Intensity Values—VTCSH LED Vehicle Arrow Traffic Signal
(Omnidirectional—suitable for mounting in any orientation)

Vertical Angle (deg)	Horizontal Angle (deg)	Omnidirectional Angle (deg)	Luminous Intensity (candela)		
			300mm (12 in) Arrow Signal		
			Red	Yellow	Green
27.5	7.5	28.4	2.8	6.9	3.6
	2.5	27.6	3.3	8.2	4.3
22.5	17.5	28.2	2.9	7.2	3.8
	12.5	25.6	5.0	12.4	6.4
	7.5	23.7	7.1	17.7	9.2
	2.5	22.6	8.5	21.2	11.1
17.5	22.5	28.2	2.9	7.2	3.8
	17.5	24.6	6.0	15.0	7.8
	12.5	21.4	10.5	26.1	13.6
	7.5	19.0	15.1	37.7	19.7
12.5	2.5	17.7	18.2	45.3	23.7
	22.5	25.6	5.0	12.4	6.4
	17.5	21.4	10.5	26.1	13.6
	12.5	17.6	18.3	45.7	23.9
7.5	7.5	14.5	26.7	66.5	34.7
	2.5	12.7	32.1	80.1	41.8
	27.5	28.4	2.8	6.9	3.6
	22.5	23.7	7.1	17.7	9.2
	17.5	19.0	15.1	37.7	19.7
2.5	12.5	14.5	26.7	66.5	34.7
	7.5	10.6	38.9	97.0	50.6
	2.5	7.9	47.0	117.1	61.1
	27.5	27.6	3.3	8.2	4.3
	22.5	22.6	8.5	21.2	11.1
	17.5	17.7	18.2	45.3	23.7
2.5	12.5	12.7	32.1	80.1	41.8
	7.5	7.9	47.0	117.1	61.1
	2.5	3.5	56.8	141.6	73.9

Note 1: Luminous intensity values for equivalent up and down vertical angles are the same.

Note 2: Luminous intensity values for equivalent left and right horizontal angles are the same.

Note 3: Tabulated values of luminous intensity are rounded to the first decimal place.

Figure 1

General Configuration of LED Vehicle Arrow Traffic Signal Icon:

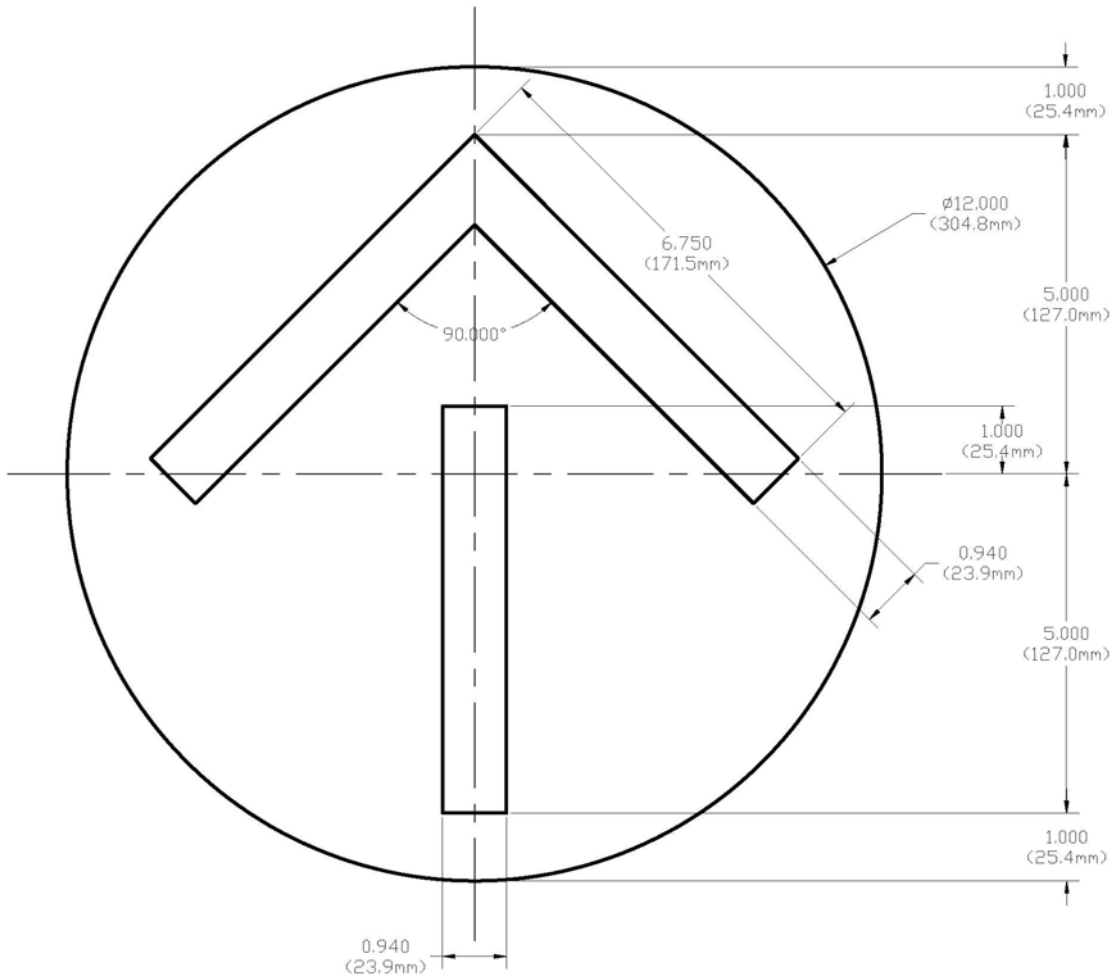

Figure 1: General Configuration of LED Vehicle Arrow Traffic Signal Icon
(Dimensions are shown in inches and (mm))